

VEHICLE		PIONEER		CONNECTOR		TRAY HEIGHT ADDED (mm/in)		
RAM 1500 Crew Cab w/ RAM BOX DT Gen 5 SHORT BED 5ft7		52113		RTD4		349/14		
VEHICLE NOTES								
REGION	AUS	NZ	USA	CA	SA	UK	EU	ZA
AVAILABILITY	x	x	✓	✓	x	x	x	x
RUNNING DATES	-	-	2019-	2019-	-	-	-	-

VISIT THE ONLINE CALCULATOR FOR CURRENT SYSTEM LOAD LIMIT DATA



DYNAMIC LOAD LIMIT (ON AND OFF-ROAD):
 *USE THE VEHICLE MANUFACTURER'S MAXIMUM TRACK ALLOWANCE IF IT IS LOWER THAN THE FIGURE LISTED

 CARGO
 UP TO **90 Kg**
199 lbs

+

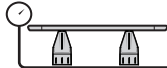
 SYSTEM WEIGHT
 UP TO **30 Kg**
66 lbs

=

 LOAD LIMIT
 UP TO **120 Kg**
265 lbs

OR



 Max kg
 *VEHICLE MANUFACTURER'S TRUCK BED UTILITY TRACK LOAD LIMIT

TOTAL STATIC LOAD LIMIT: UP TO 300 Kg / 661 lbs*

BASE

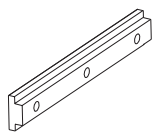
RECOMMENDED TOWER SPACING

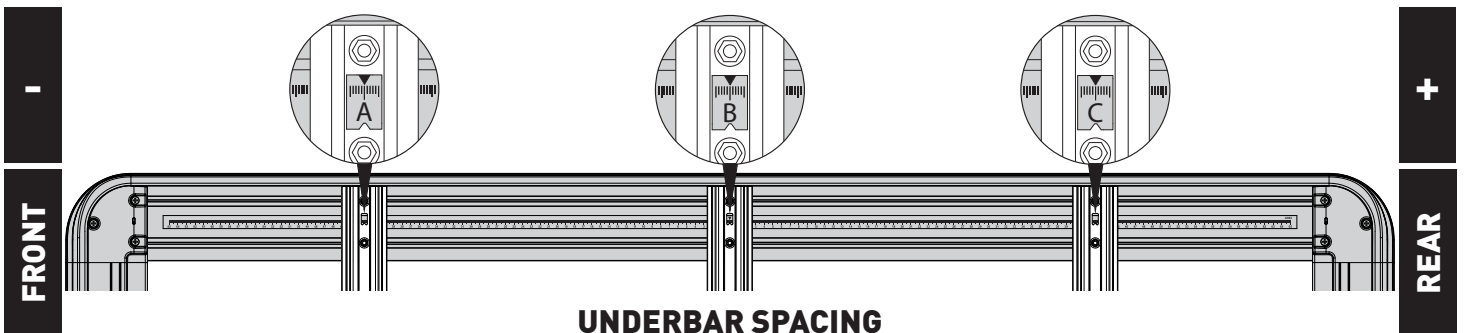
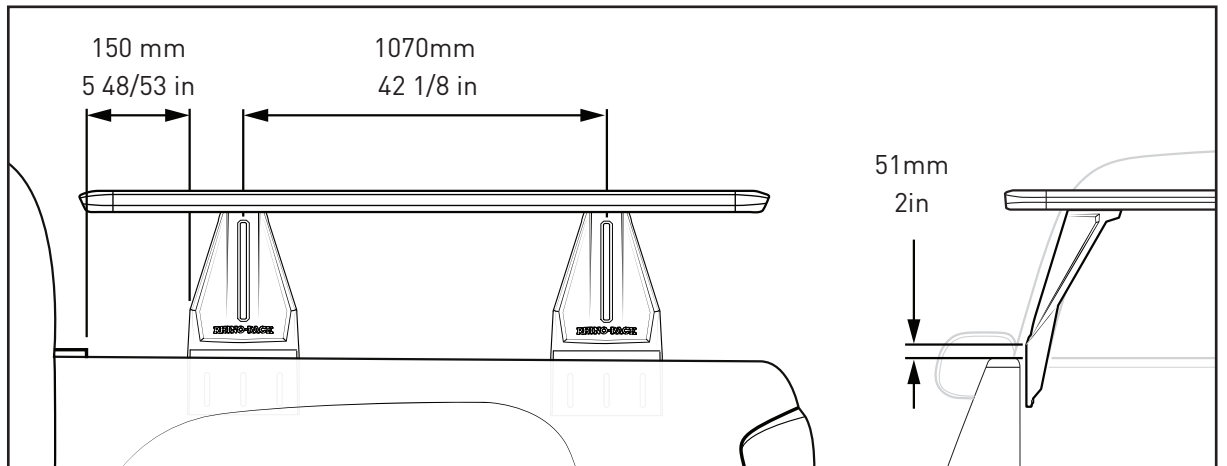
TRACK NUTS	
	
PART DETAILS	
PART NO	RD-FK3
QTY	1



UNDERBAR SPACING

BAR NO.	A	B	C	D	E	F	G
DIMENSION (CM)	-53.5	0	53.5				
CONNECTOR	RDT		RDT				

After positioning Towers and Pioneer, return to Reconn-Deck Tower Instructions.

NOTES FOR DEALERS / FITTERS

It is your responsibility to ensure these fitting instructions are given to the end user or client.

Document No: R2887
 Issue No: 1
 Issue Date: 13-May-21