

Jeep Wrangler

Required Tools

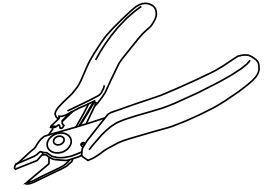

#2 Phillips Screwdriver



Side Cutters

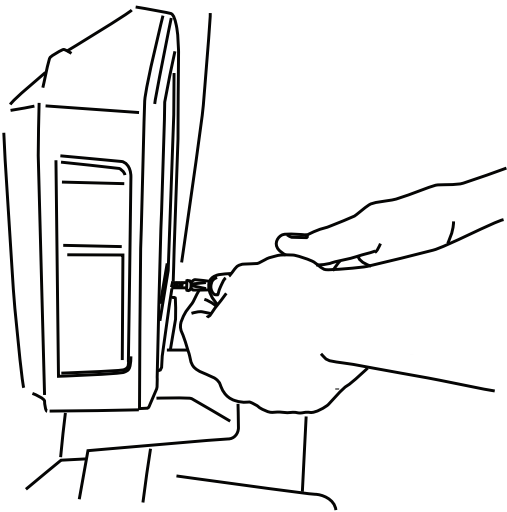

**1** To access backside of the stock fuel filler housing, remove left taillight.

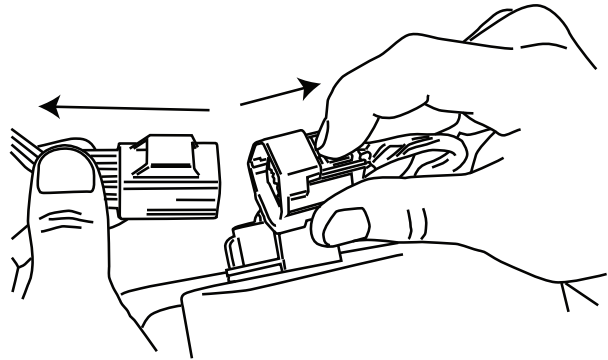

**2** Disconnect removed taillight and two screws and set aside to be reinstalled later.

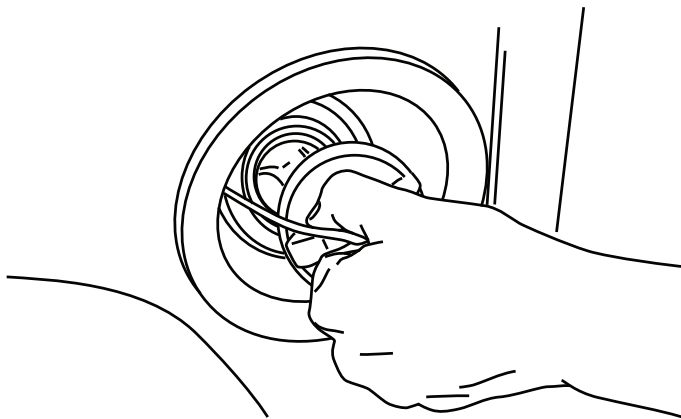

**3** Remove fuel cap.

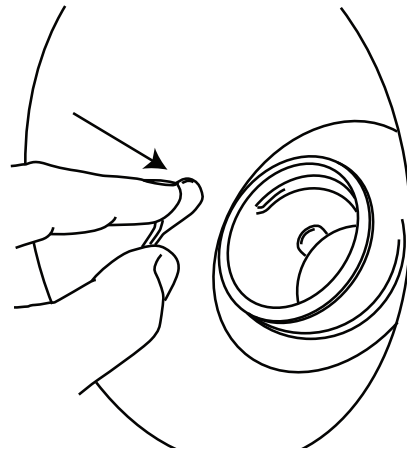

**4** Remove fuel cap tether and set fuel cap aside to be reinstalled later.

AMP RESEARCH TECH SUPPORT 1-888-983-2204 (Press 2) Monday - Friday, 6:00 AM - 5:00 PM PST

BedStep2™ is invented, designed, engineered and manufactured exclusively by AMP Research and may be covered by one of the following patents: 6,641,158; 6,830,257; 6,938,909; 7,055,839; 7,380,807; 7,398,985; 7,584,975. Made in USA © 2011 AMP Research  
Three-year limited warranty. Professional installation is recommended.

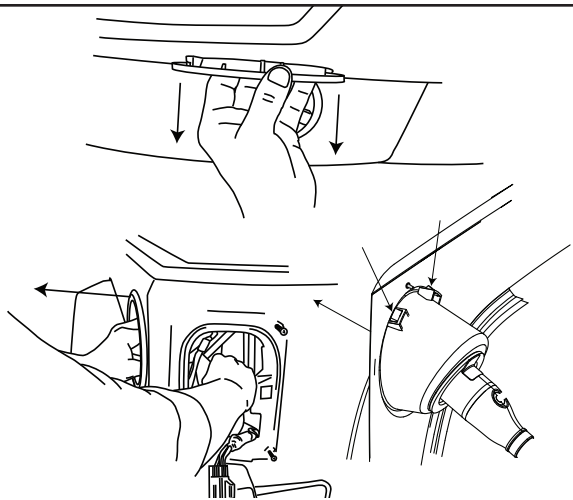

**5 Remove fuel filler housing.** With the left tailight out of the way, reach behind the sheet metal and disengage the housing retention clips, while pulling on the housing from the outside.

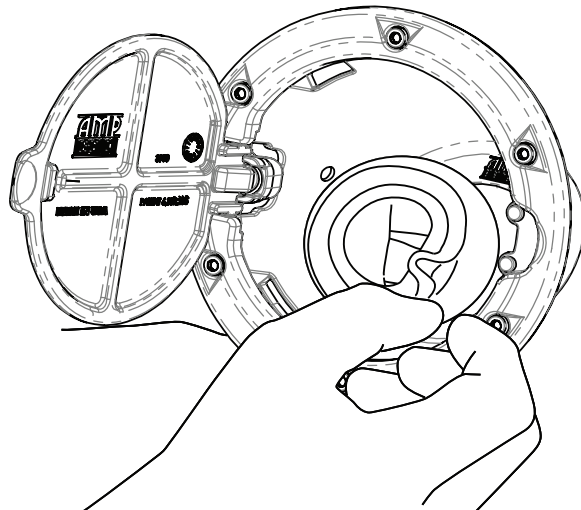

**6 Transfer Rubber Grommet.** Remove filler neck grommet from stock housing and reinstall on the new Fuel Door housing. Note the orientation of grommet.

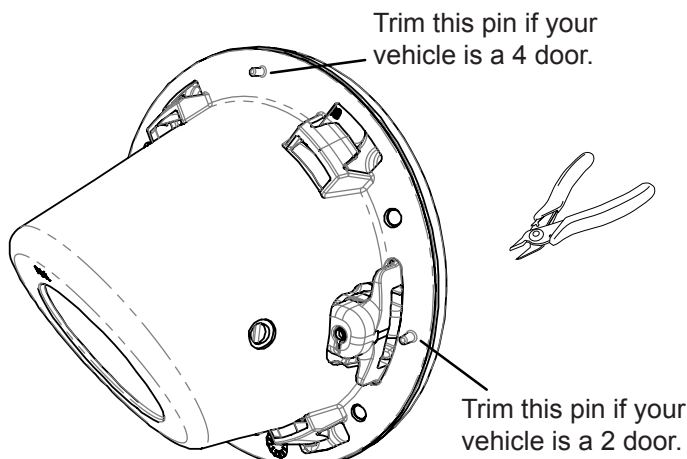

**7 Remove correct locator pin.** Cut off the correct unused locator pin, as indicated above, flush to plastic surface.

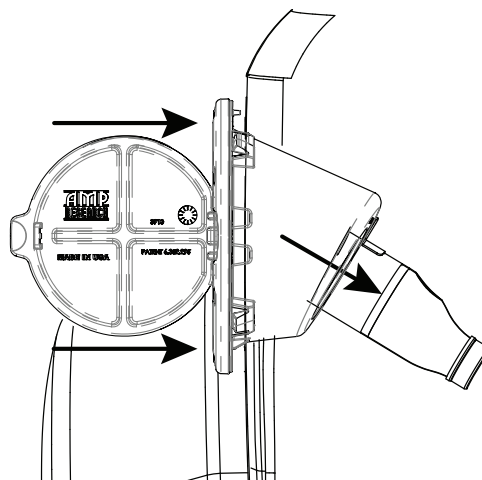

**8 Install fuel door housing while pressing grommet over fuel filler neck.**

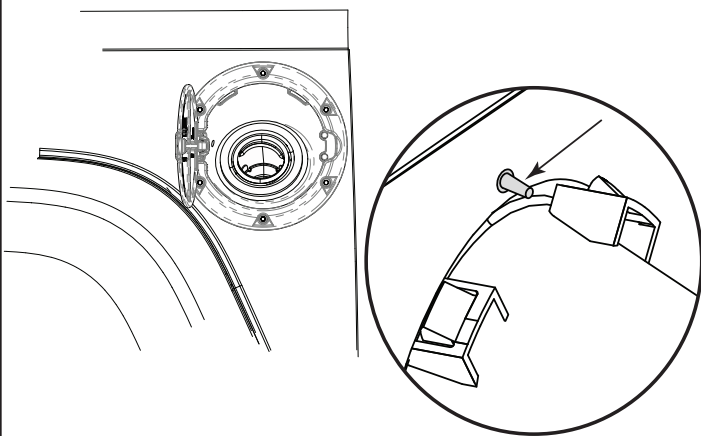

**9 Locator Pin Alignment.** Be sure that untrimmed locator pin engages with locator pin hole in sheet metal.

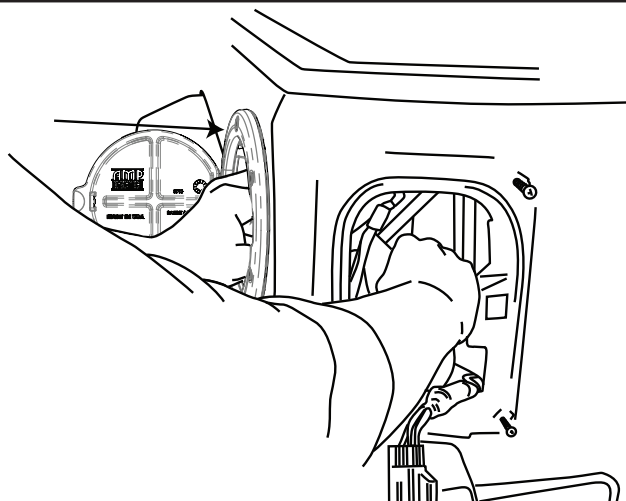

**10** With locator pin aligned, continue to press fuel door assembly into position, while holding filler neck in place.

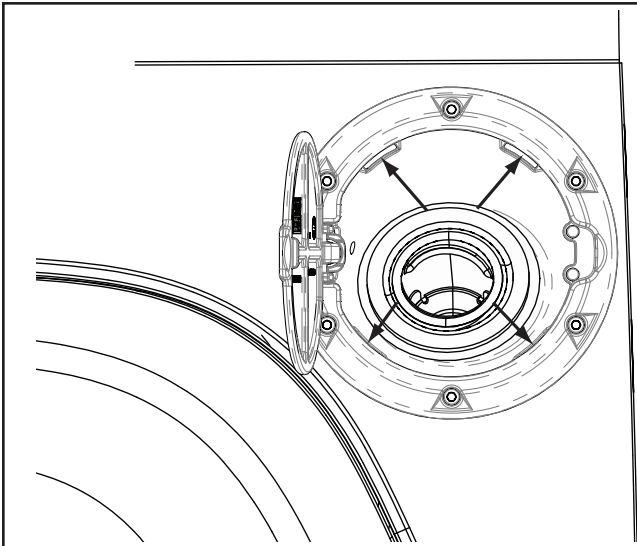

**11** Make sure all four engagement clips engage with vehicle sheet metal, pressing outward on the clips.

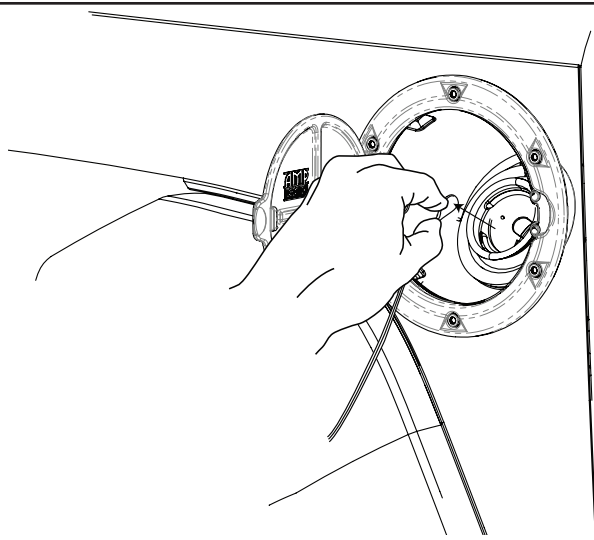

**12** Replace fuel filler cap, snapping tether into place and reinstalling cap onto filler neck.

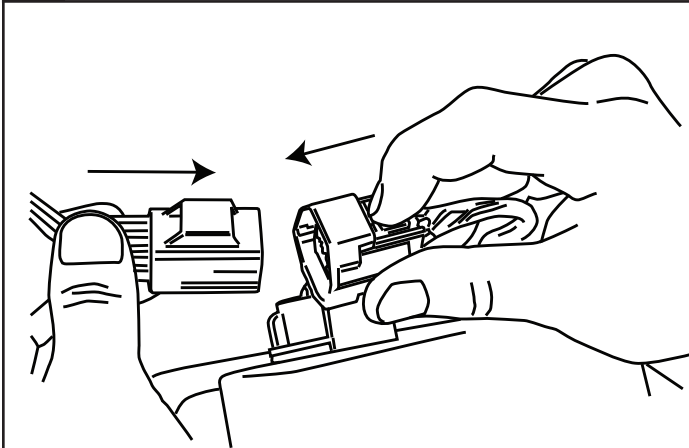

**13** Reconnect taillight connector.

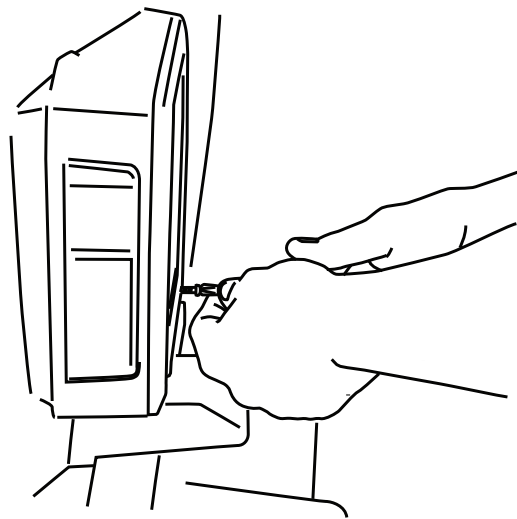

**14** Reinstall taillight.

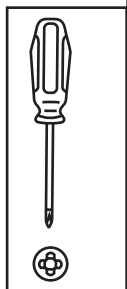

**Final Fitment and function check.** Fuel door should open and close smoothly, with hinge mechanism giving the lid two positive resting positions, fully open and fully closed. See final page for warranty information.

**15**

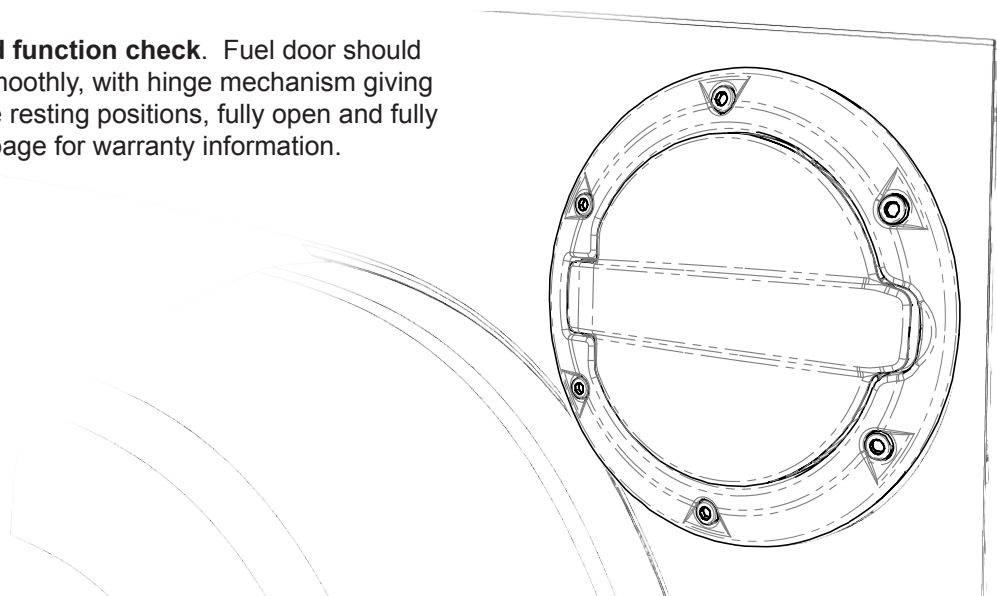



# DIE-CAST ALUMINUM FUEL DOOR

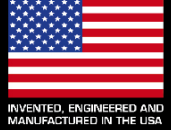

## AMP RESEARCH LIMITED WARRANTY

AMP RESEARCH warrants this product to be free from defects in material and workmanship for THREE (3) YEARS FROM DATE OF PURCHASE, provided there has been normal use and proper maintenance. This warranty applies to the original purchaser only. All remedies under this warranty are limited to the repair replacement of the product itself, or the repair or replacement of any component part thereof, found by the factory to be defective within the time period specified. The decision to repair or replace is wholly within the discretion of the manufacturer.

This warranty specifically excludes labor. If you have a warranty claim, first you must call our factory at the number below for instructions. You must retain proof of purchase and submit a copy with any items returned for warranty work. Upon completion of warranty work, if any, we will return the repaired or replaced item or items to you freight prepaid. Damage to our products caused by accidents, fire, vandalism, negligence, misinstallation, misuse, Acts of God, or by defective parts not manufactured by us, is not covered under this warranty.

ANY IMPLIED WARRANTIES OF MERCHANTABILITY AND/OR FITNESS FOR A PARTICULAR PURPOSE CREATED HEREBY ARE LIMITED IN DURATION TO THE SAME DURATION AND SCOPE AS THE EXPRESS WRITTEN WARRANTY. OUR COMPANY SHALL NOT BE LIABLE FOR ANY INCIDENTAL OR CONSEQUENTIAL DAMAGE.

Some states do not allow limitations on how long an implied warranty lasts, or the exclusion or limitation of incidental or consequential damages, so the above limitations or exclusions may not apply to you. This warranty gives you specific legal rights, and you may also have other rights that vary from state to state.

**FOR WARRANTY ISSUES WITH THIS PRODUCT PLEASE CALL AMP RESEARCH CUSTOMER SERVICE 1-888-983-2204**

## WARNING

Be sure to read and precisely follow the provided instructions when installing this product. Failure to do so could place the vehicle occupants in a potentially dangerous situation. After installing or reinstalling, re-check to insure that the product is properly installed.